



TNT Manufacturing LLC

Food Process Equipment Sales, Engineering & Service

908 Harvard Drive
Sun Prairie, WI 53590
tntmanufacturing@charter.net
www.tntmanufacturing.biz

(414) 870-2422 Sales & Service
(608) 669-4720 Administrative
(608) 318-0981 Fax

MODEL 305 HOPPER

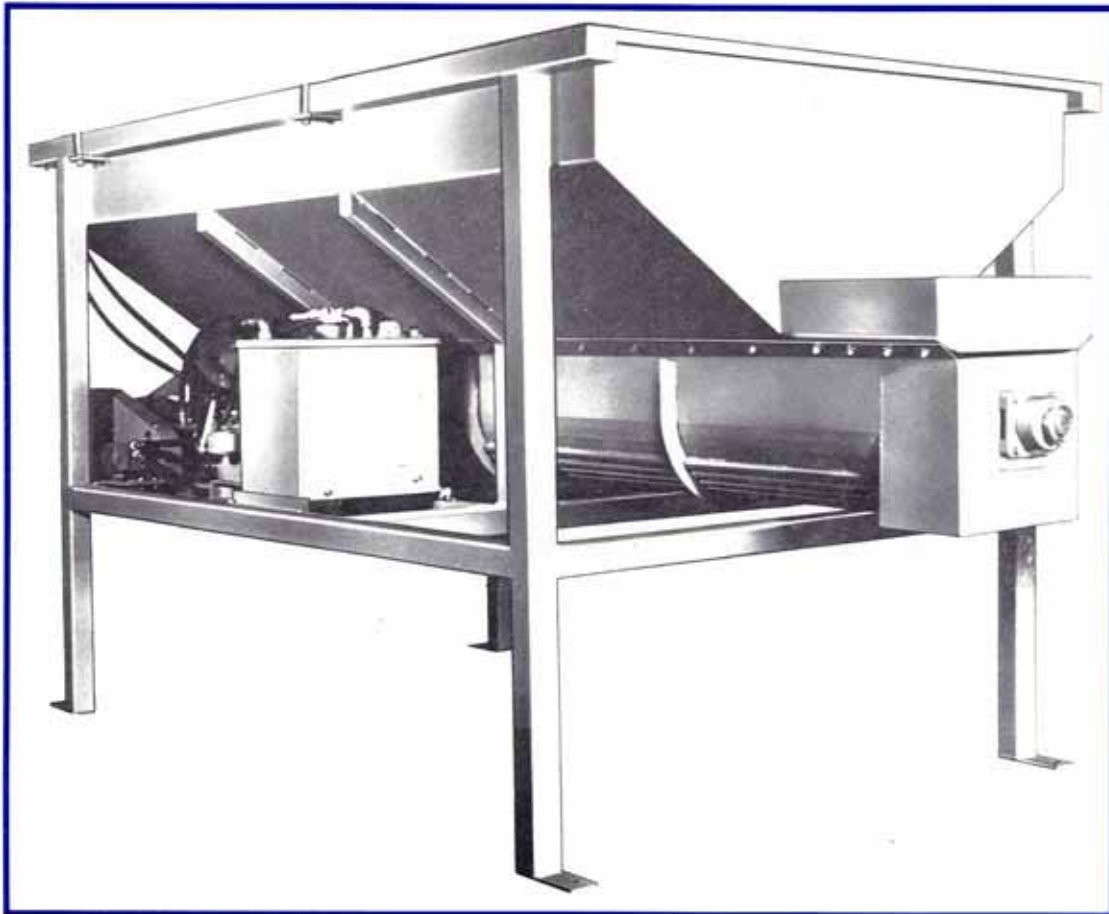

CONSTRUCTION

Sturdy construction insures long life. Either mild or stainless steel, or 3" square tube and 2" X 6" rectangular tubing.

DRIVE

Consists of a 230/460 V., 60 Hz., 3 Ph., 5 HP electric motor which powers the hydraulic system. The hydraulic system drives a single 14" diameter auger to give infinitely variable metering of product into processing line. When used with a Kusel Crate Dumper, the hydraulic system also supplies power to rotate the dumper bucket.

SANITATION

The hopper tank, as well as all structural materials are continuous welded to eliminate cracks and crevices. Unit can be easily hosed out.

ENERGY

Due to the efficiency of the auger, a small amount of horsepower is needed to move a high volume of product.

MODEL 305 HOPPER

SPECIFICATIONS

Capacity of Hopper . . . 87 Cu.ft.
Discharge Rate. Variable
Hopper Motor 2 HP, 230/460 Volt, 3
Phase, 60 Cycles.

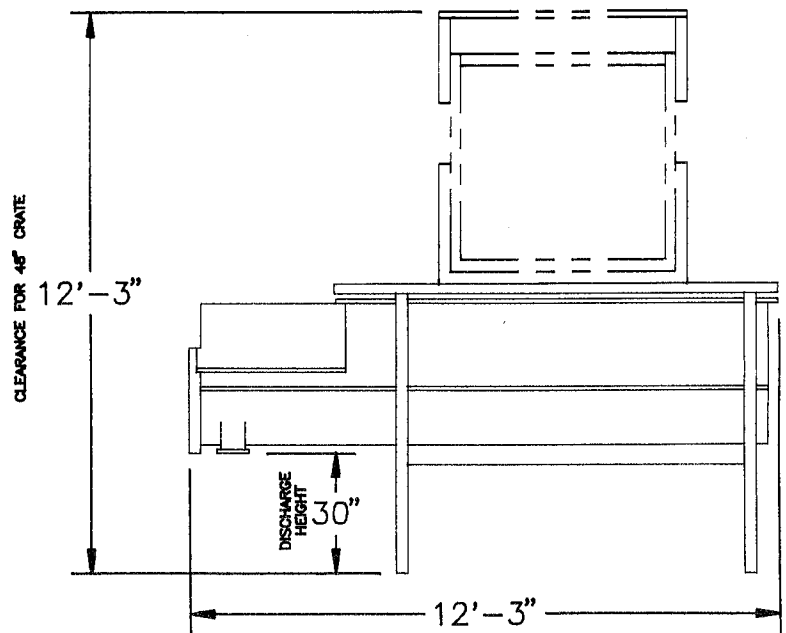
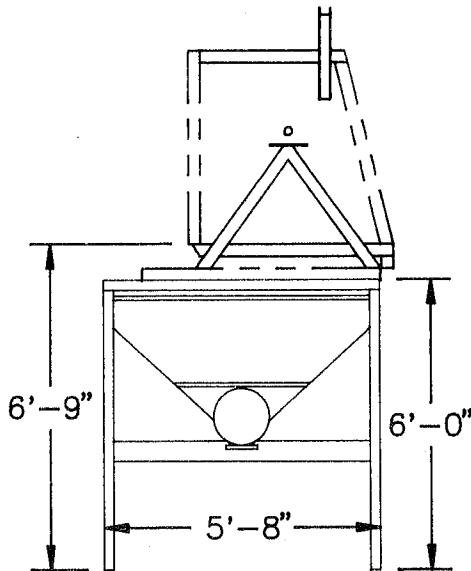
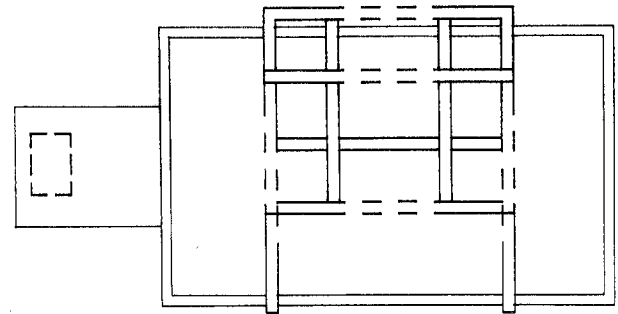

TNT Manufacturing LLC

Food Process Equipment Sales, Engineering & Service

908 Harvard Drive
Sun Prairie, WI 53590
tntmanufacturing@charter.net

(414) 870-2422 Sales & Service
(608) 669-4720 Administrative
(608) 318-0981 Fax

www.tntmanufacturing.biz